

Connecting The REVOLUTION SIMPRODUCTS Non-Motorised TQ to the BU0836 Card

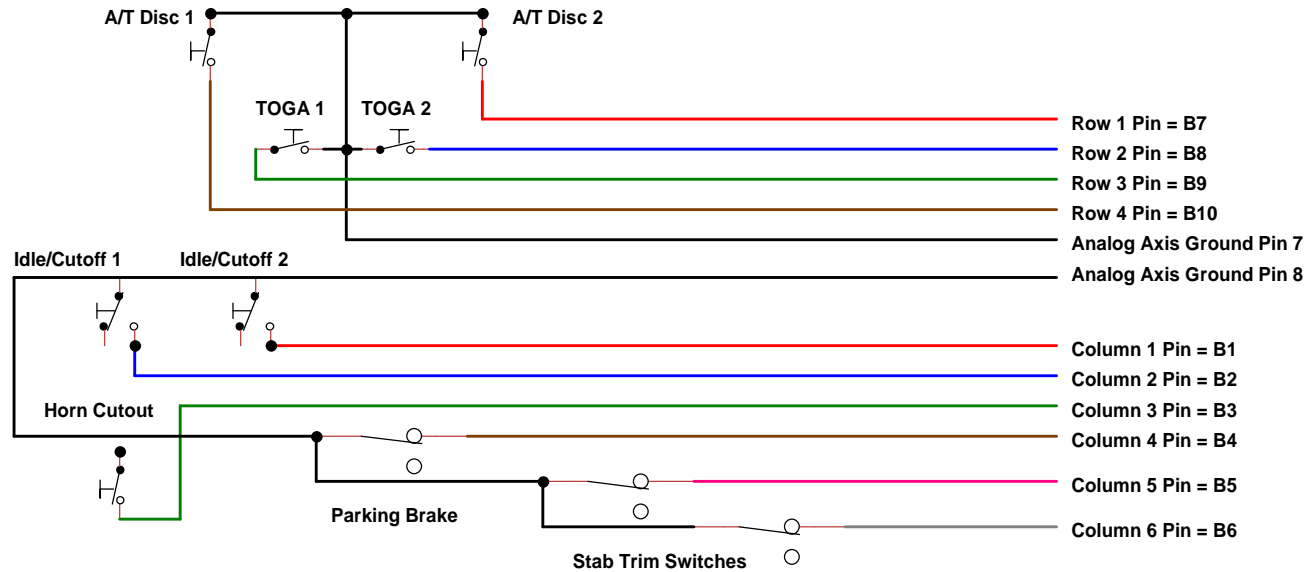

Input

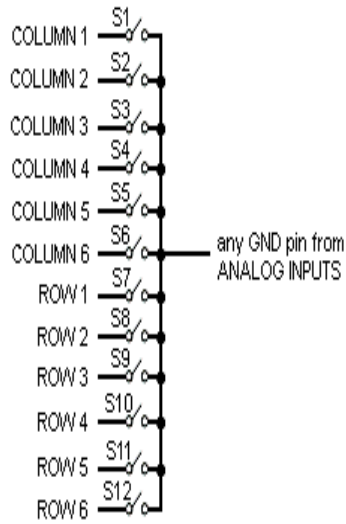
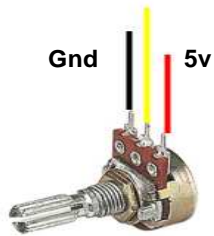

Potentiometer Connection Orientation

Simple Button Connections
 No Diodes required

BU0836 Calibrates In Windows and FSUIPC

For More Connection Options see Leo Bodnars Product Page at www.leobodnar.com

Wire Colours are for indication Only

Throttle 1
 To Analog Input 1
 X Axis

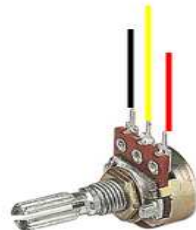

Throttle 2
 To Analog Input 2
 Y Axis

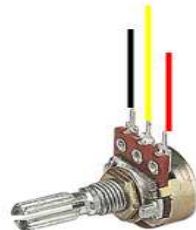

Flaps
 To Analog Input 3
 Z Axis

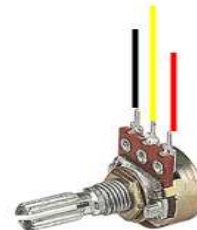

Spoiler
 To Analog Input 4
 X Rotation

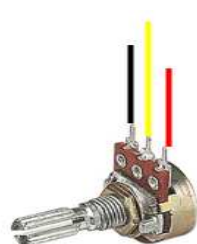

Reverser 1
 To Analog Input 5
 Y Rotation

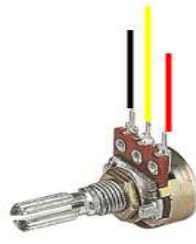

Reverser 2
 To Analog Input 6
 Z Rotation

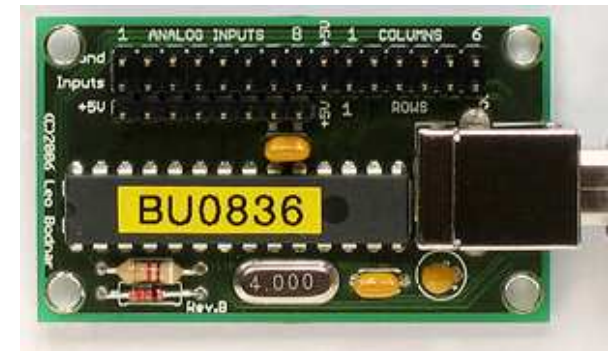
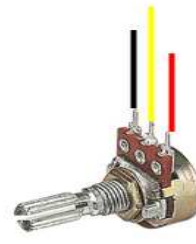

Title Revolution Simproducts TQ Wiring Diagram		
Author Ian P. Sissons ian@737ng.co.uk		
File		Document RSTQ1
Revision 1.0	Date 1st November 2010	Sheets 1 of 1